

# GJS-III-6006 Fiber Optical Splice Closure Installation Manual

Version:1.0



## 1. Scope of application

This Installation Manual suits for the Fiber Optic Splice Closure (Hereafter abbreviated as FOSC), as the guidance of proper installation.

The scope of application is: aerial and wall-mounting. The ambient temperature ranges from -40 to 65°C.

## 2. Basic structure and configuration

### 2.1 Dimension and capacity

Outside dimension (LxWxH)	280x200x90 (mm)
Weight (excluding outside box)	1200g-1500g
Number of inlet/outlet ports	max. 4 pieces
Diameter of fiber cable	Φ8—Φ14 (mm)
Capacity of FOSC	Bunchy: 6—96 (Cores)

### 2.2 Main components

No.	Name of components	Quantity	Usage	Remarks
1	FOSC cover	1 piece	Protecting fiber cable splices in whole	Internal diameter: 205x146 (mm)
2	FOSC bottom	1 piece	Fixing reinforced core, fiber cable and FOST	Internal diameter: 205x146 (mm)
3	Fiber optic splice tray (FOST)	max. 4 pieces (bunchy)	Fixing heat shrinkable protective sleeve and holding fibers	Suitable for: Bunchy:6,12,24(cores)
4	Integrated seal fitting	1 set	Sealing between FOSC cover and FOSC bottom	
5	Port plug	2 pieces	Sealing empty ports	
6	Earthing deriving device	1 set	Deriving metallic components of fiber cable in FOSC for earthing connection.	Configuration as per requirement.

### 2.3 Main accessories and special tools

No.	Name of accessories	Quantity	Usage	Remarks
-----	---------------------	----------	-------	---------

1	Heat shrinkable protective sleeve		Protecting fiber splices	Configuration as per capacity
2	Nylon tie		Fixing fiber with protective coat	Configuration as per capacity
3	Seal tape	1 roll	Enlarging diameter of fiber cable which fits in with seal fitting	Configuration as per specification
4	Hanging hook	1 set	For aerial use	Configuration as per requirement
5	Fixing device	1 set		Configuration as per requirement
6	Earthing wire	1 piece	Putting through between earthing devices	To put through while required
7	Abrasive cloth	1 piece	Scratching fiber cable	
8	Labeling paper	1 piece	Labeling fiber	
9	Special wrench	1 piece	Fixing octagonal nut (plastic)	
10	Buffer tube	To be decided by customers	Hitched to fibers and fixed with FOST, managing buffer	Configuration as per requirement
11	Desiccant	1 bag	Put into FOSC before sealing for desiccating air.	

### 3. Necessary tools for installation

#### 3.1 Supplementary materials (to be provided by operator)

Name of materials	Usage
Scotch tape	Labeling, temporarily fixing
Ethyl alcohol	Cleaning
Gauze	Cleaning

#### 3.2 Special tools (to be provided by operator)

Name of tools	Usage
Fiber cutter	Cutting off fibers
Fiber stripper	Strip off protective coat of fiber cable
Combo tools	Assembling FOSC

### 3.3 Universal tools (to be provided by operator)

Name of tools	Usage and specification
Band tape	Measuring fiber cable
Pipe cutter	Cutting fiber cable
Electrical cutter	Take off protective coat of fiber cable
Combination pliers	Cutting off reinforced core
Screwdriver	Crossing/Paralleling screwdriver
Scissor	
Waterproof cover	Waterproof, dustproof
Metal wrench	Tightening nut of reinforced core

### 3.4 Splicing and testing instruments (to be provided by operator)

Name of instruments	Usage and specification
Fusion Splicing Machine	Fiber splicing
OT DR	Splicing testing
Provisional splicing tools	Provisional testing

Notice: The above-mentioned tools and testing instruments should be provided by the operators themselves.

#### 4. Installation flow chart

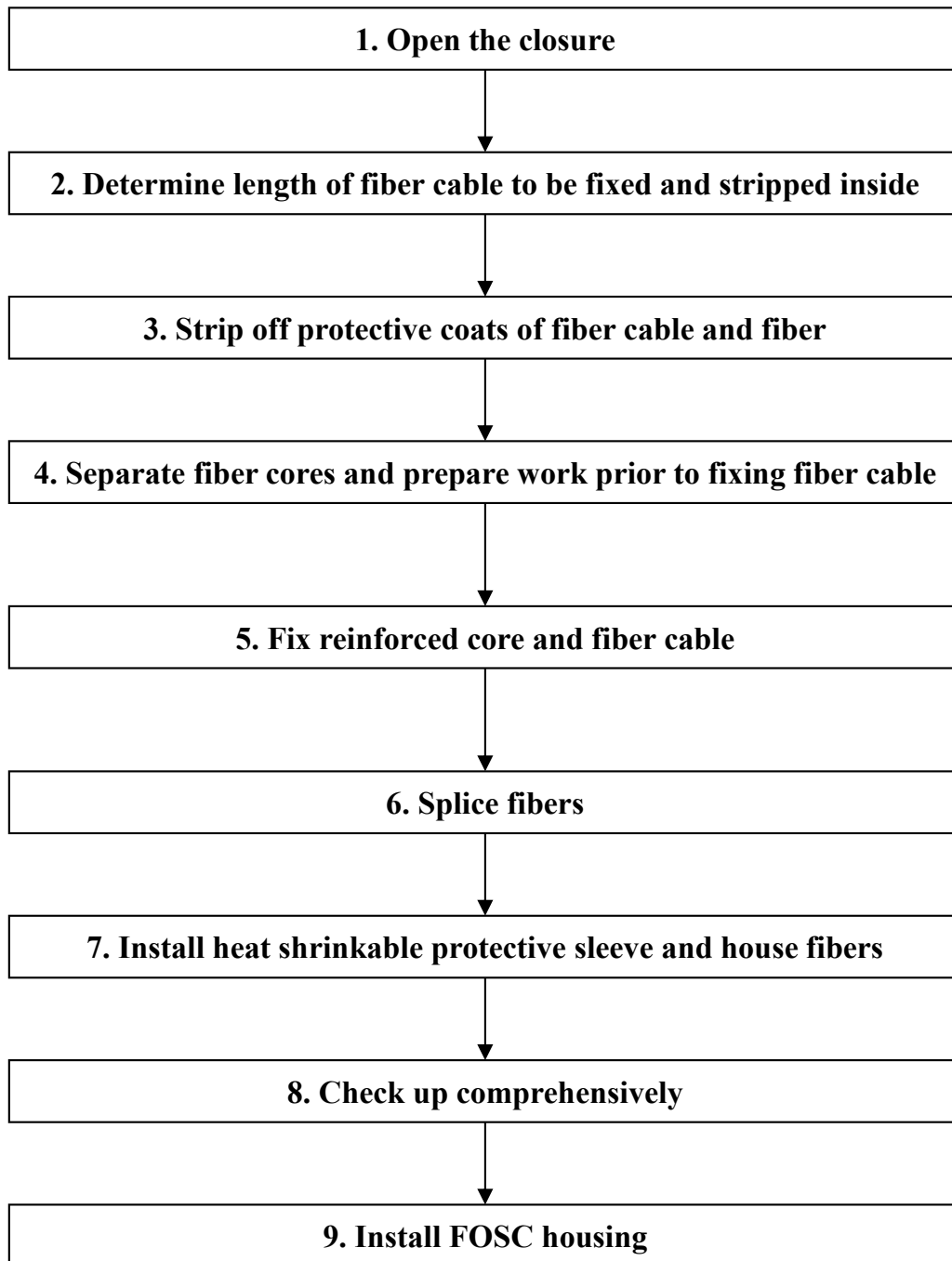

## 5. The process of installing FOSC

### 5.1 Step One - Open the closure

- 5.1.1 Cleaning the locale and determine where to install the FOSC and then place fiber cables required.
- 5.1.2 Check whether the main components and accessories have been well prepared inside the package.
- 5.1.3 Open the closure by demounting the fixing bolt (5 pieces) of the housing, then succeed in opening the closure.
- 5.1.4 See Drawing 1

**Important issues:** If the weather condition is not good enough, then a tent must be pitched for waterproof and dustproof.

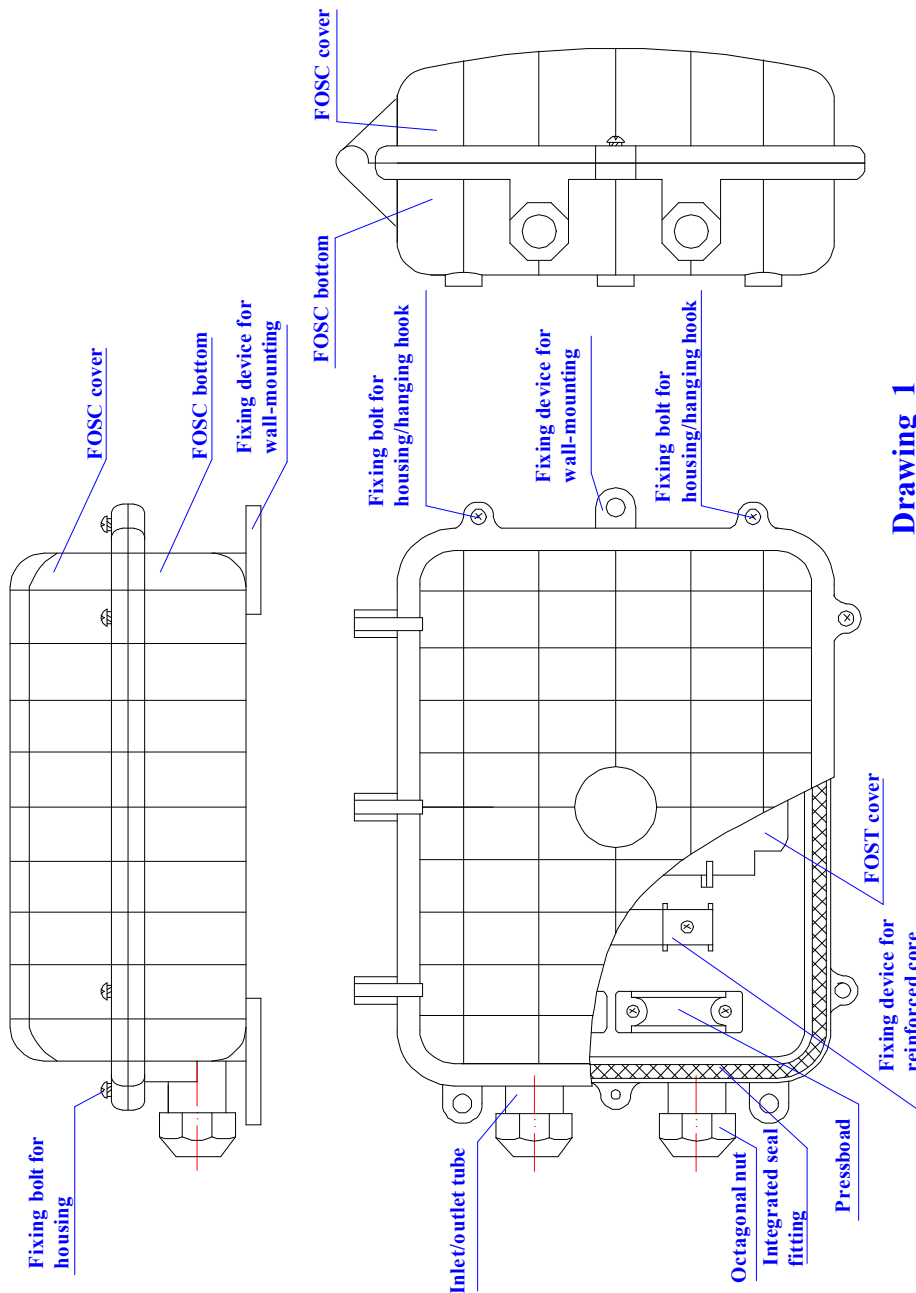

**Drawing 1**

## 5.2 Step Two -Determine length of fiber cable to be fixed and stripped inside FOOSC

- 5.2.1
- ①. Fiber cable in 70mm length: the distance from seal fitting to fiber cable pressboard
  - ②. Fiber cable in 1720mm length: it is used to be wound and spliced after stripping.
  - ③. Fiber with protective coat in 120mm length: the distance from the fixing point of fiber cable to the fixing point of FOST (fiber optic splice tray).
  - ④. Fiber in 1600mm length: after stripping off the protective coat, it is to be wound inside the FOST after splicing with other fibers

5.2.2 See Drawing 2

### Important issues:

1. Reserve enough length of fiber cable to be spliced.
2. Stripping length also could be decided by customer according to installation requirement.

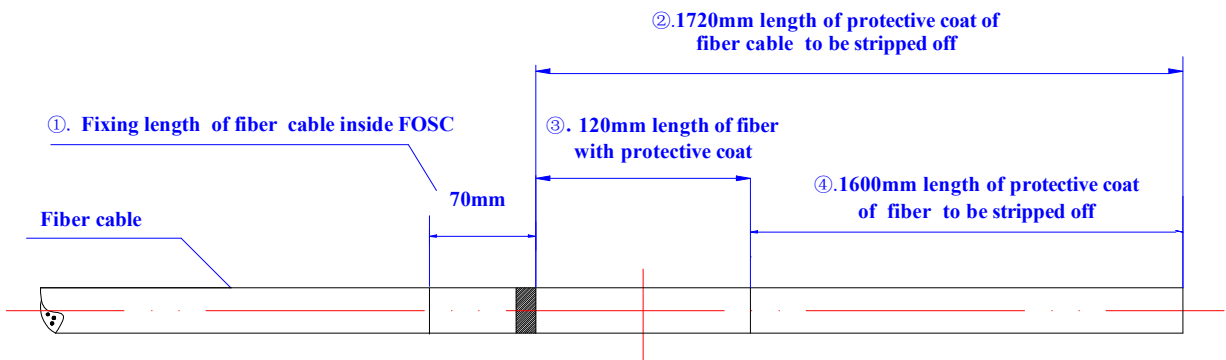

**Drawing 2**

## 5.3 Step Three – Strip off fiber protective coat of fiber cable and fiber

5.3.1 Strip off protective coat of fiber cable from the temp. locating mark with the cutter and the stripper, please refer to Drawing 2 for stripping length. Stripping length also could be decided according to installation requirement

5.3.2 See Drawing 3.

**Important issues:** If it is difficult to strip off all the protective coat of fiber cable at one time, strip it off section by section to avoid fiber breakage.

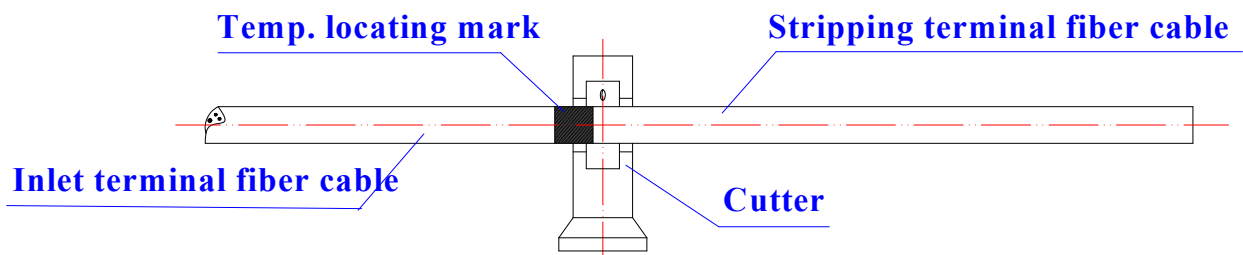

**Drawing 3**

## 5.4 Step Four – Separate fiber cores and prepare work prior to fixing fiber.

- 5.4.1 Wind 2 layers of insulation tape on protective coat of fiber core. Meanwhile, get rid of the stuffing to separate fiber and clean them. Form a ring with the diameter of 100mm or so and fix it on the fiber temporarily by adhesive tape.
- 5.4.2 This FOSC is provided with 2 inlet/outlet tubes, each of which suit for 1 piece of fiber cable with max. diameter  $\phi 14\text{mm}$  or 2 pieces of fiber cable with max. diameter  $\phi 11\text{mm}$ . The corresponding port plug could be taken out according to number of fiber cable actually required. The max. number of fiber cables with diameter  $\phi 11\text{mm}$  to be installed is 4.
- 5.4.3 Reserve reinforced core in 30mm length and cut off the unnecessary ones.
- 5.4.4 See Drawing 4

**Important Issues:** Cut off reinforced core with a special cutting plier.

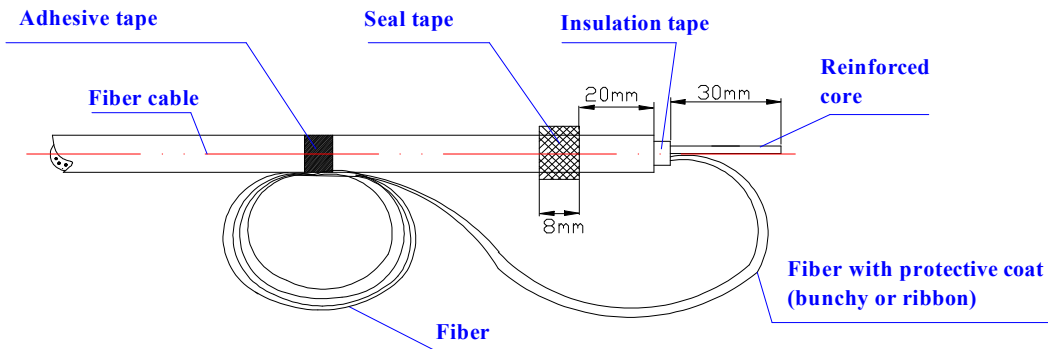

**Drawing 4**

## 5.5 Step Five - Fix reinforced core and fiber cable

- 5.5.1 After deciding number of fiber cable inlet/outlet, demount the nut and gasket of the corresponding inlet/outlet tube. Insert them into fiber cables in sequence, which are to be inserted into inlet/outlet tube then.
- 5.5.2 Fix fiber cable to fixing device of fiber cable (while diameter of fiber cable is small, enlarge the diameter with insulation tape), then fix the reinforced core to the fixing device of the reinforced core.
- 5.5.3 Push the first gasket into inlet/outlet tube, then enlarge the diameter of fiber cable with seal tape (to fit in with internal diameter of inlet/outlet tube). Then push the second gasket and the seal tape into inlet/outlet tube, which is to be tightened with octagonal nut.
- 5.5.4 See Drawing 5

**Important issues:** before the seal tape is used for enlarging the diameter of fiber cable, it should be scratched and to be cleaned with abrasive cloth and ethyl alcohol.



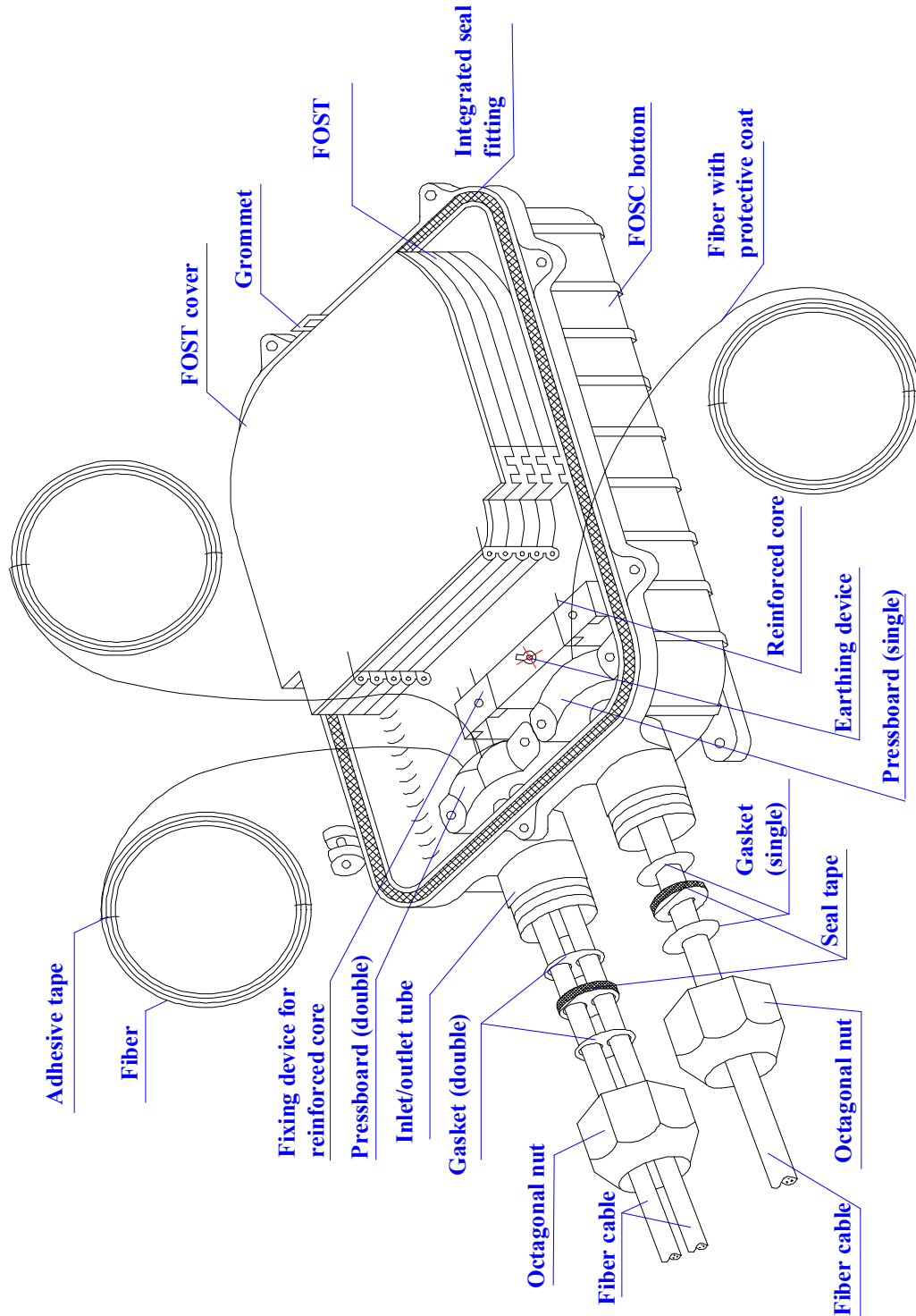

**Drawing 5**

## 5.6 Step Six - Splice fibers

5.6.1 Follow user manual of fusion splicing machine to splice fiber.

**Important issue:** pay attention to the twist and bend of fiber.

## 5.7 Step Seven -Install heat shrinkable protective sleeve and house fibers

5.7.1 When having completed splicing the fibers, the first fiber ring should be housed

on the farthest side of FOST, the remaining fiber should be wound, forming a ring with diameter not less than 80mm. then put it into FOST (Fiber Optic Splice Tray) together with heat shrinkable protective sleeve.

( Firstly fix heat shrinkable protective sleeve into the slot, then enlarge the diameter of fiber ring properly.)

5.7.2 see Drawing 6

**Important issue:** pay attention to the twist and bend of fiber.

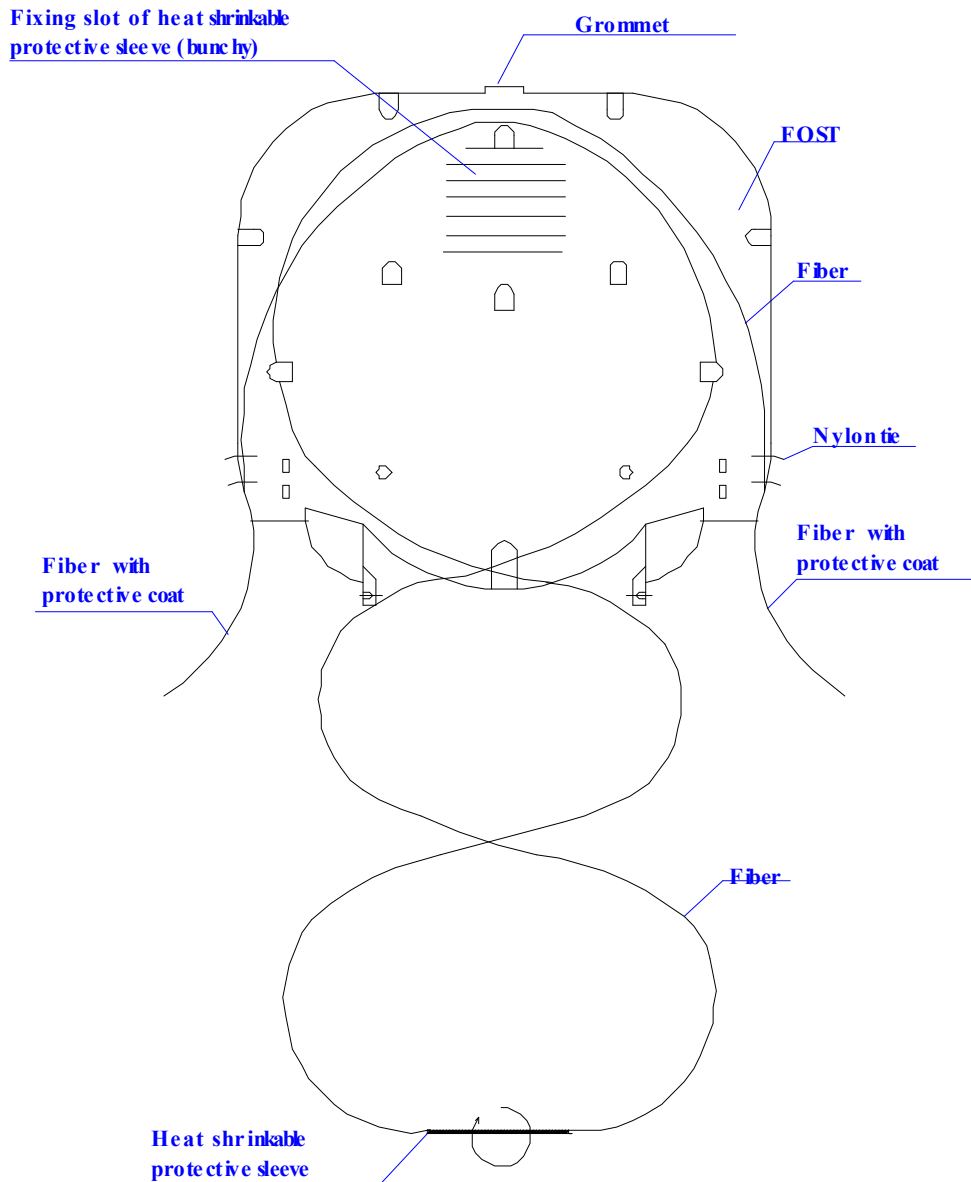

**Drawing 6**

## 5.8 Step Eight - Check up comprehensively

To ensure the technical requirements, the following instructions must be followed:

- 5.8.1 Fibers with protective coat are fixed with nylon tie at the entrance of FOST.
- 5.8.2 Grommet should be pressed from inside to outside in order to properly install FOST.
- 5.8.3 Check whether the internal tighteners and bolt of reinforced core is well tightened

5.8.4 Check whether integrated seal fitting is installed neatly and smoothly without any breakage. If not, level it up with seal tape.

5.8.5 See Drawing 7.

**Important issues:** If any problems occur, they should be solved right away.

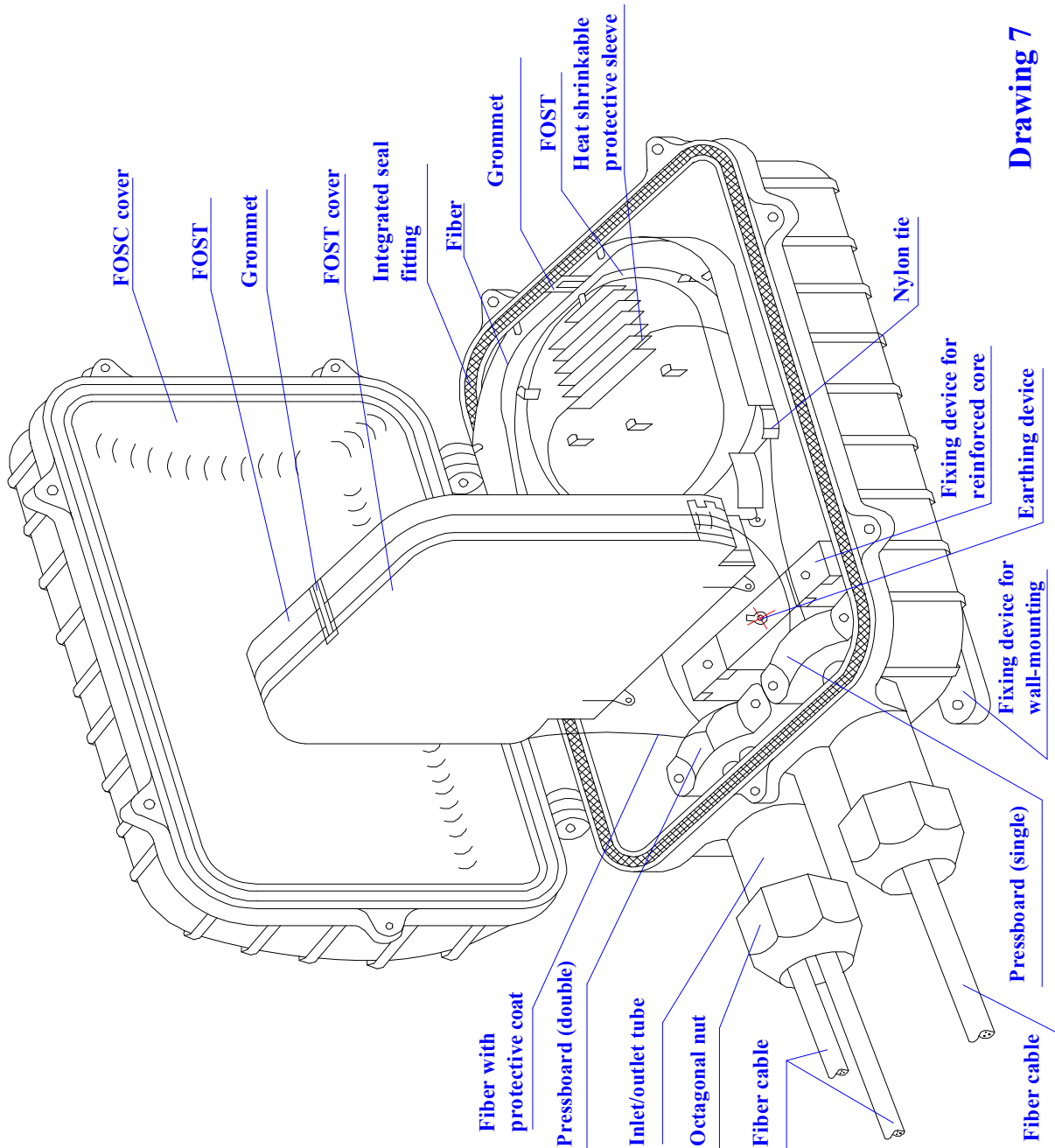

**Drawing 7**

## 5.9 Step Nine – Install FOSC housing

5.9.1 Tighten fixing bolts of the housing

5.9.2 Tighten octagonal nuts

5.9.3 Either wall mounting or aerial mounting is possible according to the actual installation requirement.

- ① Wall mounting application: fixing device for wall mounting should be installed at the bottom of FOOSC, which is to be fixed with plastic intumescent screw and bolts.
- ② Aerial mounting application: fix hanging hook on the wall.

5.9.3. See drawing 8

**Important issues:** 1. Clean the housing  
2. Tighten bolts in sequence.

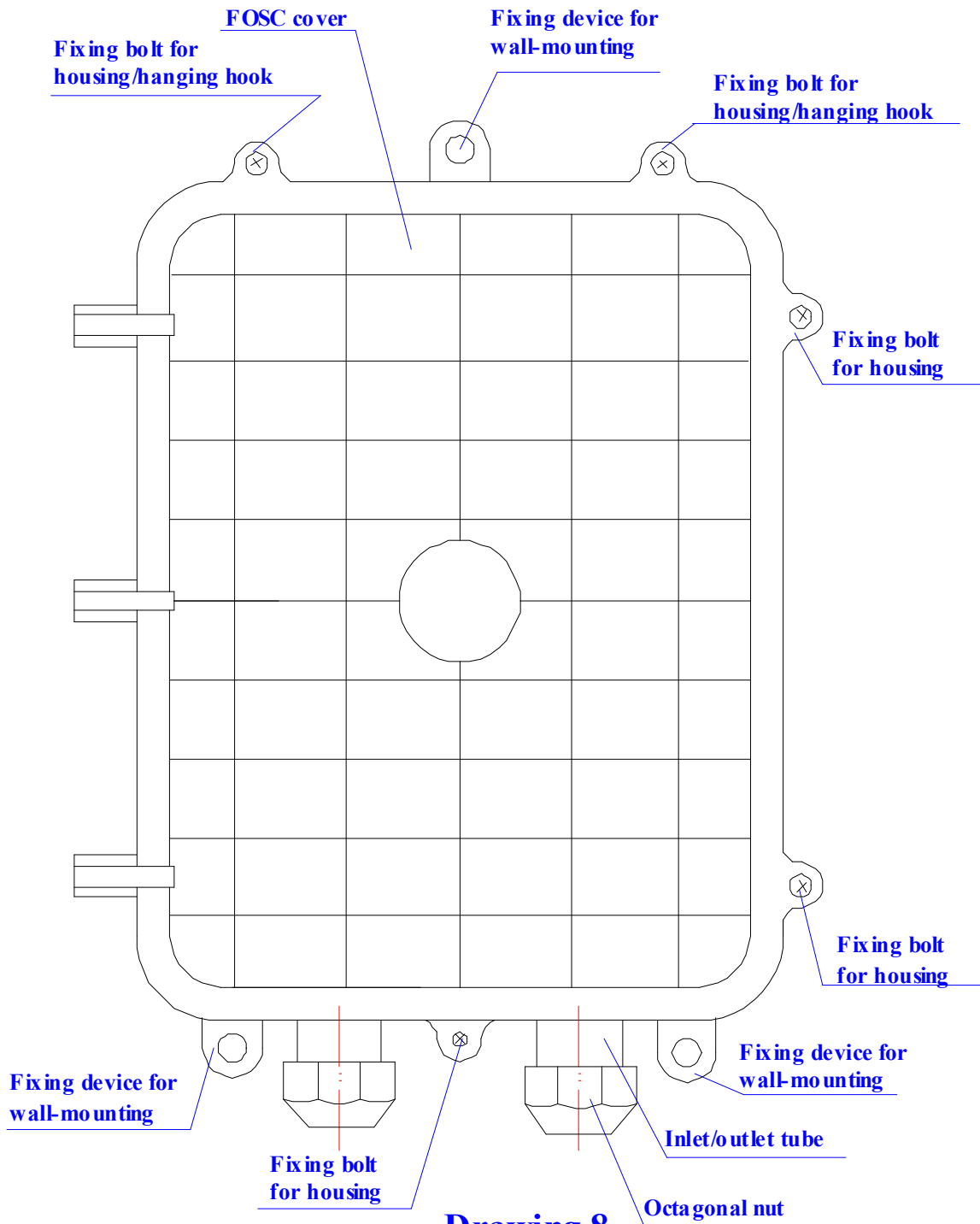

**Drawing 8**

## 6. Fiber Optic Splice Closures (FOSC) inspecting and testing items

Inspecting item	Technical Requirements	Inspecting type	
		Routine test (Before leaving factory)	Type test
<b>Package</b>	Each small package contains one fiber optic splice closure, together with its accessories, tools, installation manual and packing list.	full	At least 3 sets sampled each time
<b>Appearance</b>	Intact in shape, no burrs, bubbles, chaps, pores, warps, impurities and other defects, all background colors should be even and continual.		
<b>Sign</b>	There is a clear sign on the housing, such as name and model of the product, etc.		
<b>Fiber storage device</b>	The fibers reserved are to be winded in fiber optic splice tray (FOST), the length of fibers housed in FOST is >1.6m, the curved radius is >30mm. During the installation and maintenance, there should be no attenuation on fibers.	At least 3 sets sampled each time	
<b>Electrical jointing device</b>	Inside FOOSC: metallic components of fiber cables has the functions of electrical putting through, earthing connection and disconnecting. It is possible to install earthing deriving device outside the housing		
<b>Sealing performance</b>	After sealing according to the stipulated operation procedures, the injected air pressure is 100KPa $\pm$ 5Kpa, when immersed in clean water of normal temperature for 15 minutes, there should be no air bubbles, then observed for 24 hours, there should be no change of air pressure.		
<b>Re-sealing performance</b>	After reopening and resealing according to the stipulated operation procedures, the injected air pressure is 100KPa $\pm$ 5Kpa, when immersed in clean water of normal temperature for 15 minutes, there should be no air bubbles, then observed for 24 hours, there should be no change of air pressure.		
<b>Pull</b>	Bearing pull is $\geq$ 800N at axle orientation, there should be no breakage on the housing.		
<b>Punching</b>	Bearing pressure of 2000N/10cm for 1 minutes, there should be no breakage on the housing		
<b>Impact</b>	Bearing impact energy of 16N•m, 3 times of impacts there should be not breakage on the housing		

<b>Bending</b>	The spot between the FOSC and seal fitting can bear bending tension of 150N at bending angle of $\pm 45^{\circ}$ for 10 circles, there should be no breakage on the housing		
<b>Torsion</b>	Bearing torsion 50N•m, 10 circle at torsion angle $\pm 90^{\circ}$ . There should be no breakage on the housing.		
<b>Temperature circle</b>	Injected air pressure of 60KPa $\pm$ 5 KPa, the temperature circle ranging from -40°C~+65°C, 10 times of the circular tests (one circular consists of high temperature for 2 hours + indoor temperature for 2 hours + low temperature for 2 hours + indoor temperature for 2 hours ) when the pressure declines, the amplitude is $\cong$ 5Kpa, immerse the swatch in clean water of normal temperature for 15 minutes, there should be no air bubbles.		
<b>Voltage resistance strength</b>	After sealing the FOSC according to the stipulated operation procedures, immerse it in clean water of normal temperature in 1.5m depth for 24 hours, there should be no breakdown or arc over between the metallic components of the FOSC, between metallic components and the ground at DC 15KV for 1 minutes.		
<b>Isolating resistance</b>	After sealing the FOSC according to stipulated operation procedure, immerse it in clean water in 1.5m depth for 24h, the isolating resistance between the metallic components of the FOSC, between the metallic components and the ground should be $\cong$ $2 \times 10^4 M \Omega$ .		