

# GJS-I-2025 Fiber Optical Splice Closure Installation Manual

Version:1.0



## 1. Scope of application

This Installation Manual suits for GJS-I-2025 Splitter Splice Closure (Hereafter abbreviated as FOSC), as the guidance of proper installation. GJS-2025 splitter closure can install various kind of PLC or box splitter; it is especially for FTTH project. The scope of application is: aerial, underground, wall-mounting, handhole-mounting and duct-mounting. The ambient temperature ranges from -40°C to +65°C.

## 2. Basic structure and configuration

### 2.1 Dimension and capacity

Outside dimension (H× W×L)	323×192×345mm
Weight (excluding outside box)	About 4.0 kg
Number of inlet/out ports	Drop cable 24 pcs, Fiber cable 8 pcs
Diameter of fiber cable	Drop cable $\Phi 5\sim\Phi 9$ mm, fiber cable $\Phi 8\sim\Phi 22$ mm
Capacity of FOSC	Bunchy: 12-192cores

### 2.2 Main components

No.	Name of components	Quantity	Usage	Remarks
1	FOSC cover	1 piece	Protecting fiber cable splices in whole	H× W×L 276×176×245mm
2	Fiber optic splice tray (FOST)	Max.16 trays	Fixing heat shrinkable protective sleeve and holding fibers	Bunchy: 6,12 cores
3	Splitter tray		Fixing splitter	Configuration as per requirement
4	Fiber holding tray	1 pcs	Hold the fiber with sleeves	
5	Base	1set	Fixing internal and external structure	
6	Plastic hoop	1 set	Fixing between FOSC cover and base	
7	Sealing ring	1 set	Big gasket ring is used to seal FOSC cover and base. Small gasket ring is used to seal entry/exit tube	
8	Hose clamp	8 pcs	Use for fixing the fiber cable	Configuration as per requirement

9	Plastic gasket	6 set	Protect elastic seal rings from corruption	
10	Pressure testing valve	1 set	After inject air, it is used for pressure testing and sealing testing	Configuration as per requirement
11	Earthing deriving device	1 set	Deriving metallic parts of fiber cables in FOSC for earthing connection	Configuration as per requirement

### 2.3 Main accessories and special tools

No.	Name of accessories	Quantity	Usage	Remarks
1	Heat shrinkable protective sleeve		Protecting fiber splices	Configuration as per capacity
2	Nylon tie		Fixing fiber with protective coat	Configuration as per capacity
3	Earthing wire	1 pc	Putting through between earthing devices	
4	Special wrench	2 pcs	Installing and tightening nut of reinforced core and nut (plastic) of entry/exit tube	
5	Desiccant	2 bags	Put into FOSC before sealing for desiccating air	
6	Metal wall mounting	1 set	For wall mounting	
7	Metal pole mounting	1 set	For pole mounting	
8	Buffer tube	m	Hitched to fibers and fixed with FOST, managing buffer.	Configuration as per requirement
9	Sealing tape	1 ring	For the port of straight through	
10	Insulating tape	1 roll	Enlarging diameter of fiber cable for easy fixing	

## 3. Necessary tools for installation

### 3.1 Supplementary materials (to be provided by operator)

Name of materials	Usage
Scotch tape	Labeling, temporarily fixing
Ethyl alcohol	Cleaning
Gauze	Cleaning

### 3.2 Special tools (to be provided by operator)

<b>Name of tools</b>	<b>Usage</b>
Fiber cutter	Cutting off fiber cable
Fiber stripper	Strip off protective coat of fiber cable
Combo tools	Assembling FOSC

### 3.3 Universal tools (to be provided by operator)

<b>Name of tools</b>	<b>Usage and specification</b>
Band tape	Measuring fiber cable
Pipe cutter	Cutting fiber cable
Electrical cutter	Take off protective coat of fiber cable
Combination pliers	Cutting off reinforced core
Screwdriver	Crossing/Paralleling screwdriver
Scissor	----
Waterproof cover	Waterproof, dustproof
Metal wrench	Tightening nut of reinforced core

### 3.4 Splicing and testing instruments (to be provided by operator)

<b>Name of instruments</b>	<b>Usage and specification</b>
Fusion Splicing Machine	Fiber splicing
OT DR	Splicing testing
Provisional splicing tools	Provisional testing

Notice: The above-mentioned tools and testing instruments should be provided by the operators themselves.

#### 4、 Installation flow chart

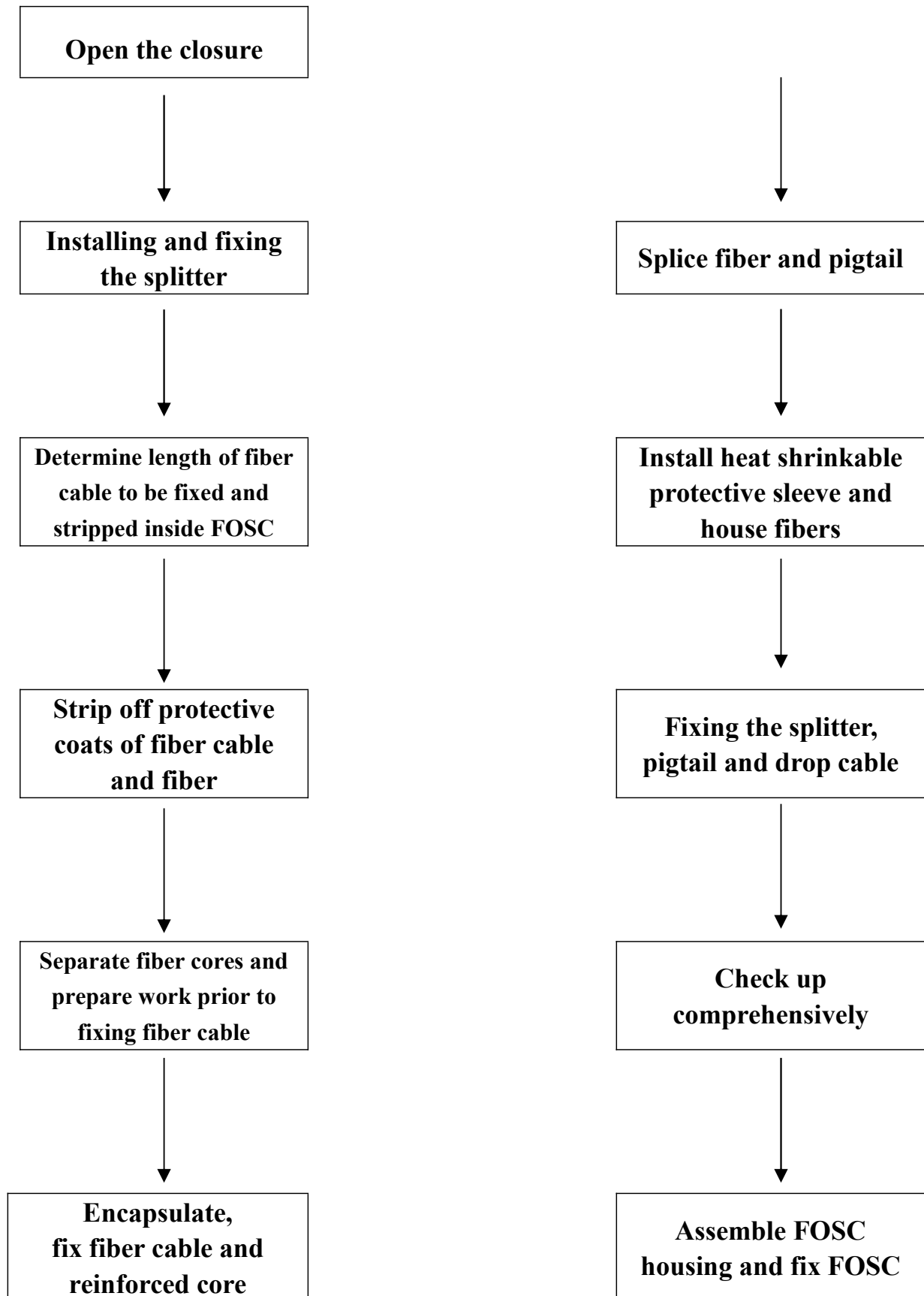

## 5. The process of installing FOSC.

### 5.1 Step one-Open the closure

Cleaning the locale and determine where to install the FOSC and then place fiber cables required. Check whether the main components and accessories have been well prepared inside the package.

Open the closure

- (1) Demount hoop fixing bolt and pull hoop locking system out, then proceed in demounting the hoop.
- (2) Pull the FOSC cover upwards out, installation could begin. See Drawing 1

**Important issues:** If the weather condition is not good enough, then a tent must be pitched for waterproof and dustproof.

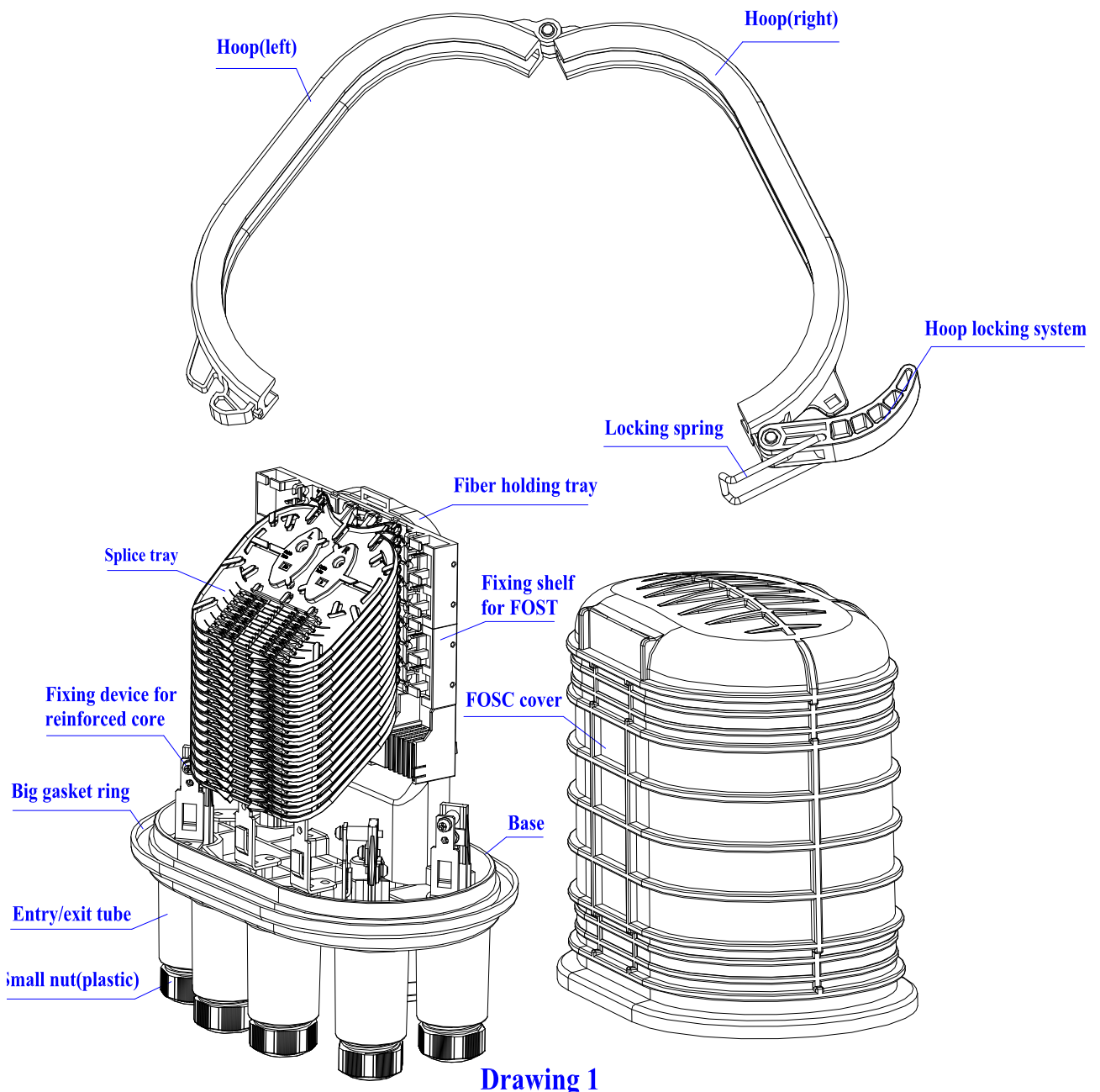

Drawing 1

## 5.2 Step two-Installing and fixing the splitter.

5.2.1 According to the customer's need to install, if you need to install a PLC optical splitter, the optical splitter can be installed in the card slot in the splitter tray, if you install more than 2 splitters, the splitter can be installed at different splitter tray. See drawing 2

### Important issues:

PLC should reserve enough fiber, and swirling the redundant fiber in the splitter tray.

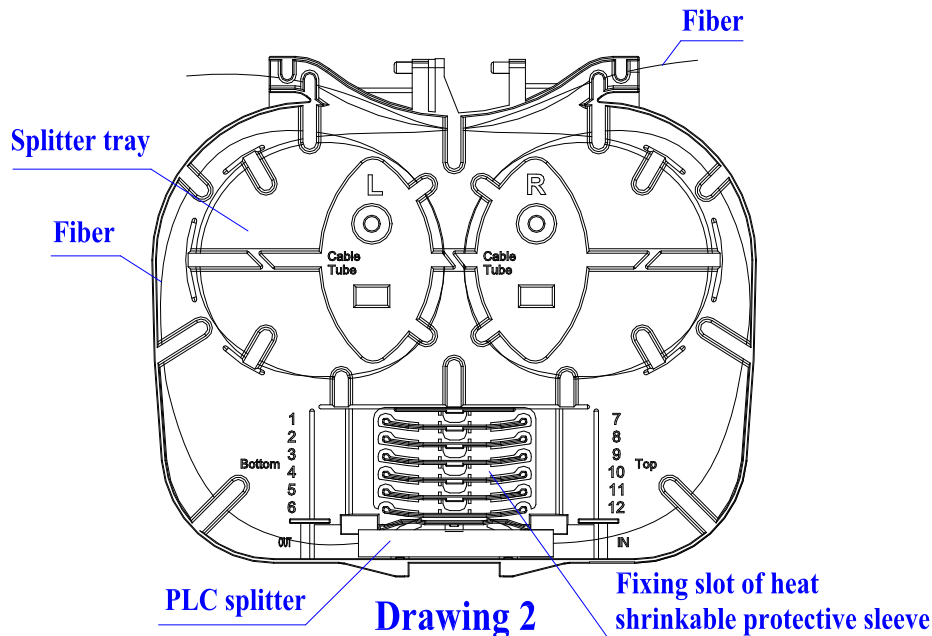

**Drawing 2**

## 5.3 Step Three - Determine length of fiber cable to be fixed and stripped inside

5.3.1 According to the requirement, the ports are installed with fiber cable or drop cable.

5.3.2 The fibers which are in the FOSC are used for branching splice. The length of stripping cable show in 3-1.

5.3.3 a part of fiber cable for straight through, a part for branching splice, The length of stripping cable show in 3-2.

### Important issues

- (1) Reserve enough fiber cable.
- (2) Determine the length of stripping cable.
- (3) The customer can decide the stripping cable length by themselves if they have other requirement.

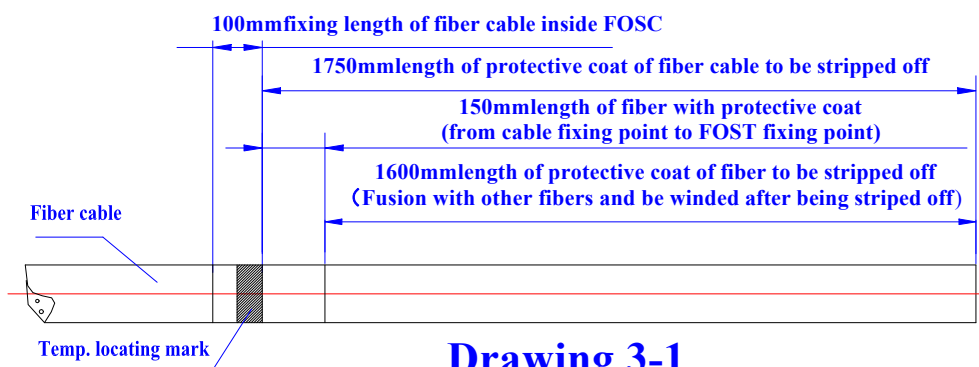

**Drawing 3-1**

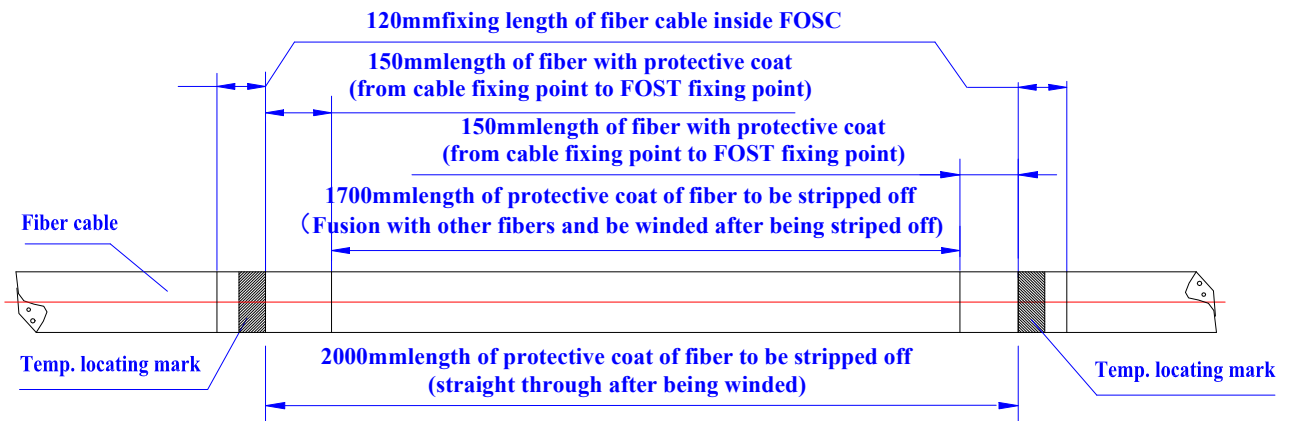

**Drawing 3-2**

### 5.4 Step four - Strip off protective coat of fiber cable and fiber

5.4.1 Strip off protective coat of fiber cable from the temp. Locating mark with the cutter and the stripper, please refer to Drawing 3 for stripping length. Stripping length also could be decided according to installation requirement. See Drawing 4.

**Important issues:** If it is difficult to pull all the protective coat of fiber cable at one time, strip it off section by section to avoid fiber breakage.

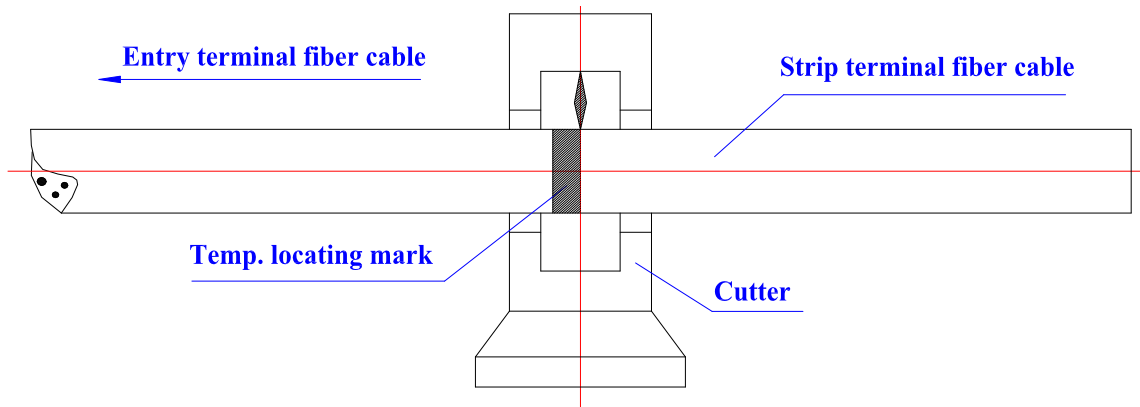

**Drawing 4**

### 5.5 Step Five - Separate fiber cores and prepares work prior to fixing fiber cable.

5.5.1 Wind 2 layers of insulation tape on protective coat of fiber core for protection.

Meanwhile, get rid of the stuffing to separate fiber core and clean them. Form a ring with the diameter of 100mm or so and fix it on the fiber cable temporarily by adhesive tape.

5.5.2 According to stripe cable, it has two kinds: (1) fibers are branched after splice ;(2)one part fibers are straight-through after coil, the others are spliced with branch fiber

5.5.3 This closure has 7 inlet/outlet ports at the end case.6 pcs of small ports can install with 1pc of max. diameter 20mm cable or 4 pcs of 5-9mm drop cable. 1pc of oval big ports can install with 1pc of max.diameter20mm for straight through, or 2 pcs of max diameter 20mm cables for branching.

5.5.4 One part of fiber need to straight through, it should choose oval port to install.

See drawing5,6

- Important issues :**
1. Inlet/outlet tubes are to be selected accurately to make it easy for splicing and sealing.
  2. Reserve reinforce core for 40mm, then cut off the unnecessary

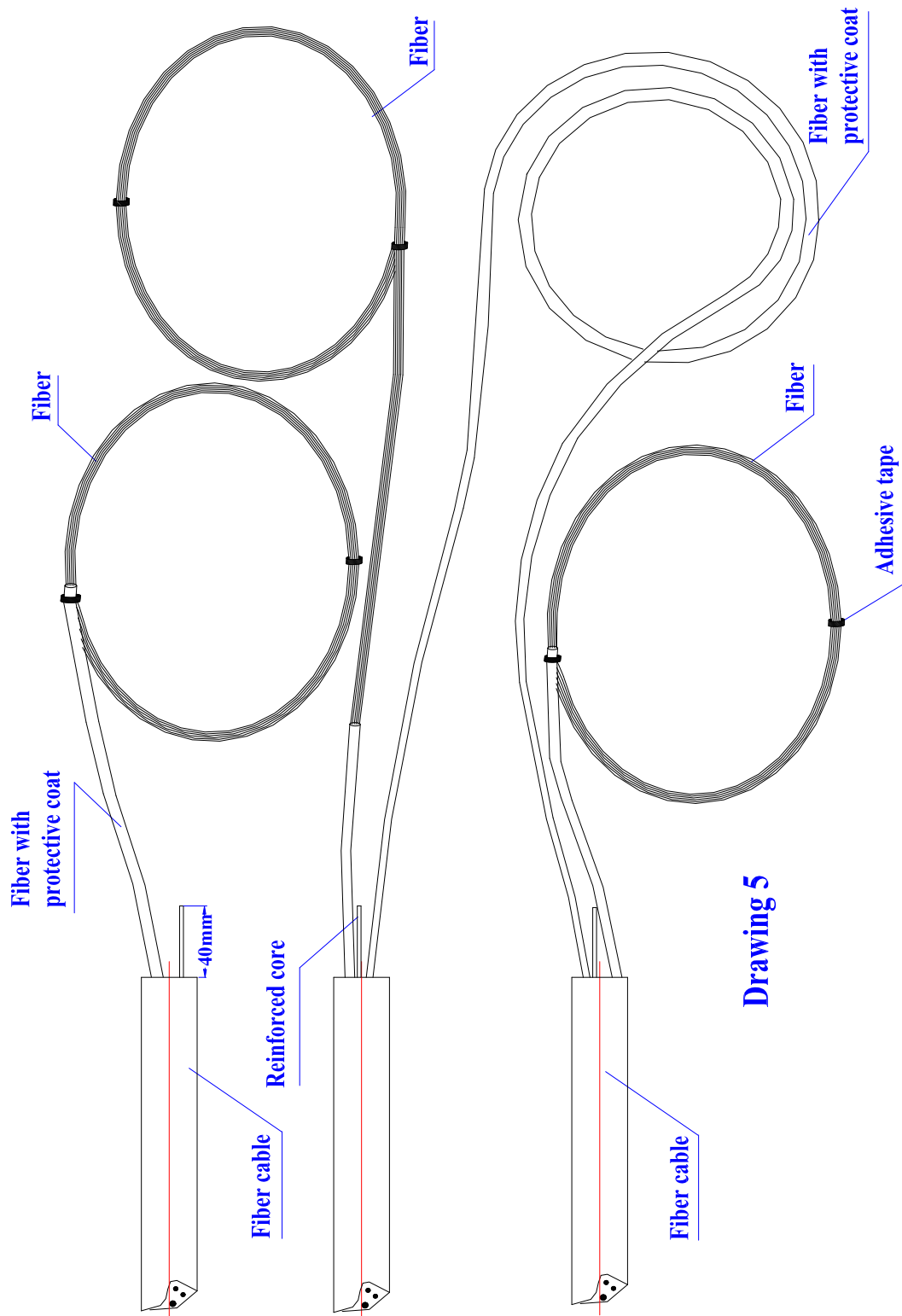

**Drawing 5**

### 5.6 Step Six - Encapsulate, fix fiber cable and reinforced core

5.6.1 Install the normal cable in the small port: according to the diameter of the cable, choose the suitable sealing ring. Demount the nut, gasket and sealing ring of the corresponding entry/exit tubes, insert them into fiber cable in sequence, and then insert fiber cables into

entry/exit cable. Fix cable and reinforced core: according to the diameter of the cable, use the suitable hose clamp jammed in the slot of reinforced core device. Then put the hose clamp on the cable, let the cable 5mm above the hose clamp, tighten the nut in order to fix the cable. After that, release the reinforced core device, through the core and screws. Finally put the small sealing gasket, gasket ring, nut through the tube, tighten the nut in order to seal properly.

5.6.2 Install the mini cable in the small port: First according to the mini cable way and put it into the sealing ring, fixed the mini cable reinforced core, and then together through cable access port, fixed mini cable components, then tighten the nut in order to seal properly.

5.6.3 The big port for straight splice and part branch: should be based on the actual installation of the cable diameter, use the appropriate double-hole sealing. Unscrew the two fastening screws, platen, double hole ring and washer, and then put the tube into the ports, At last put the gasket, double hole ring, and the plastic platen, and finally tighten two fastening screws to ensure sealing.

5.6.4 Uncutting cable and the fix the reinforced core: according to the diameter of the cable, choose the right hose clamp, jammed in the slot of reinforced core base. Then put the hose clamp on the cable, let the cable 5mm above the hose clamp, tighten the nut in order to fix the cable. After that, release the reinforced core plate, through the core and screws; fix the direct through cable in the storage tray

5.6.5. Demount the nut of fixing device of reinforced core with special wrench (plastic one), set the reinforced core into fixing slot, tighten the nut, and retighten it with metal wrench (metal wrench to be provided by operator). See drawing 6.

**Important issues: tighten the reinforce core fixing screws.**

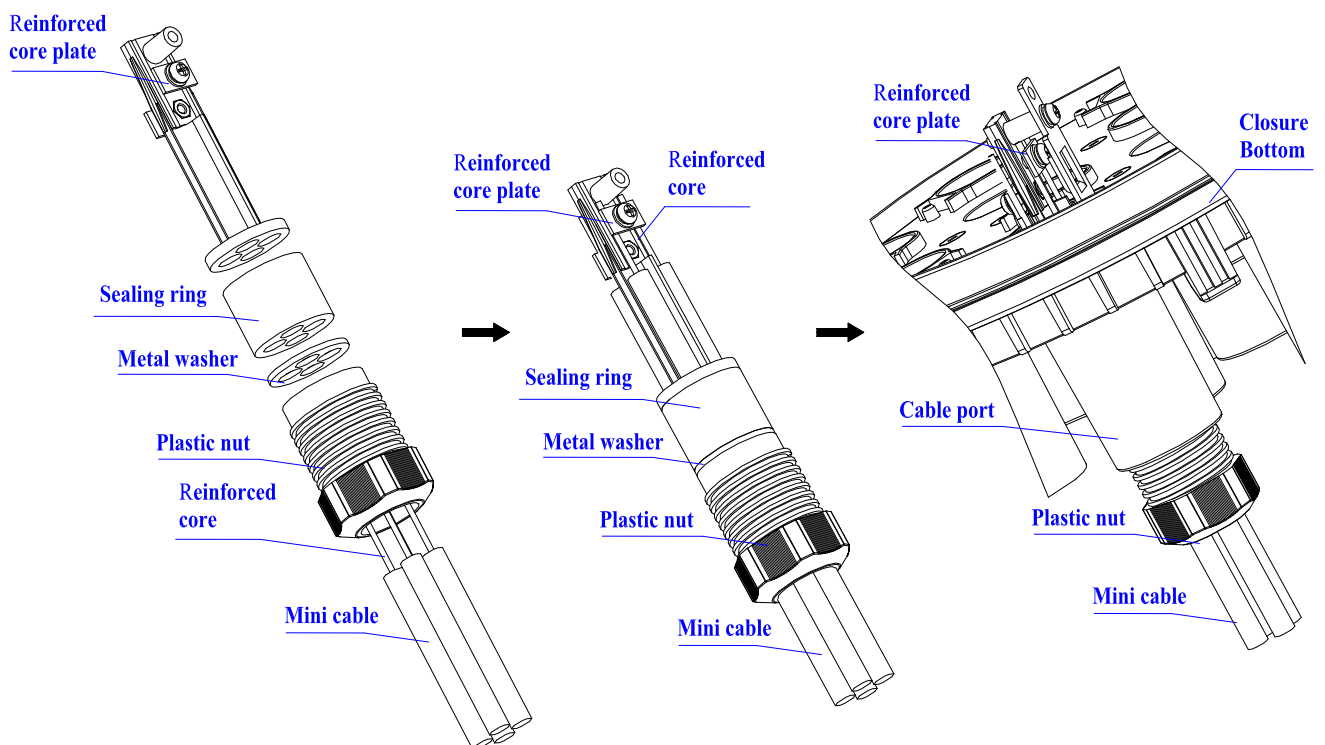

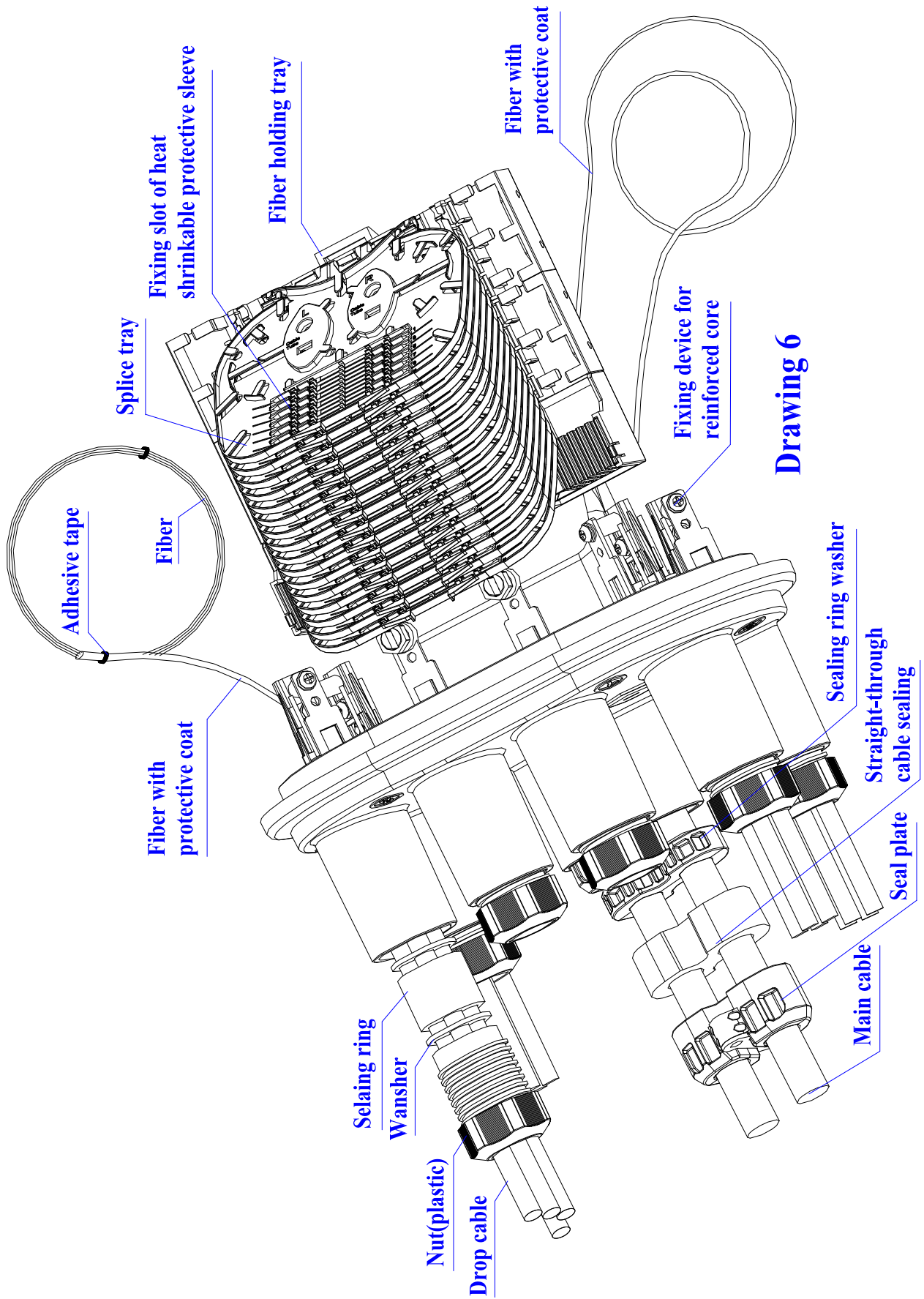

**Drawing 6**

## 5.7 Step seven - Fiber splicing

5.7.1 Follow user manual of fusion splicing machine to splice fiber.

**Important issues:** pay attention to the twist and bend of fiber

## 5.8 Step eight - Install heat shrinkable protective sleeve and house fibers

5.8.1 When having completed splicing the fibers, the first fiber ring should be housed on the farthest side of FOST, the remaining fiber should be winded, forming a ring with diameter not less than 60mm. then put it into FOST (Fiber Optic Splice Tray) together with heat shrinkable protective sleeve.( Firstly fix heat shrinkable protective sleeve into the slot, then enlarge the diameter of fiber ring properly.)

See drawing 7

**Important issue:** pay attention to the twist and bend of fiber.

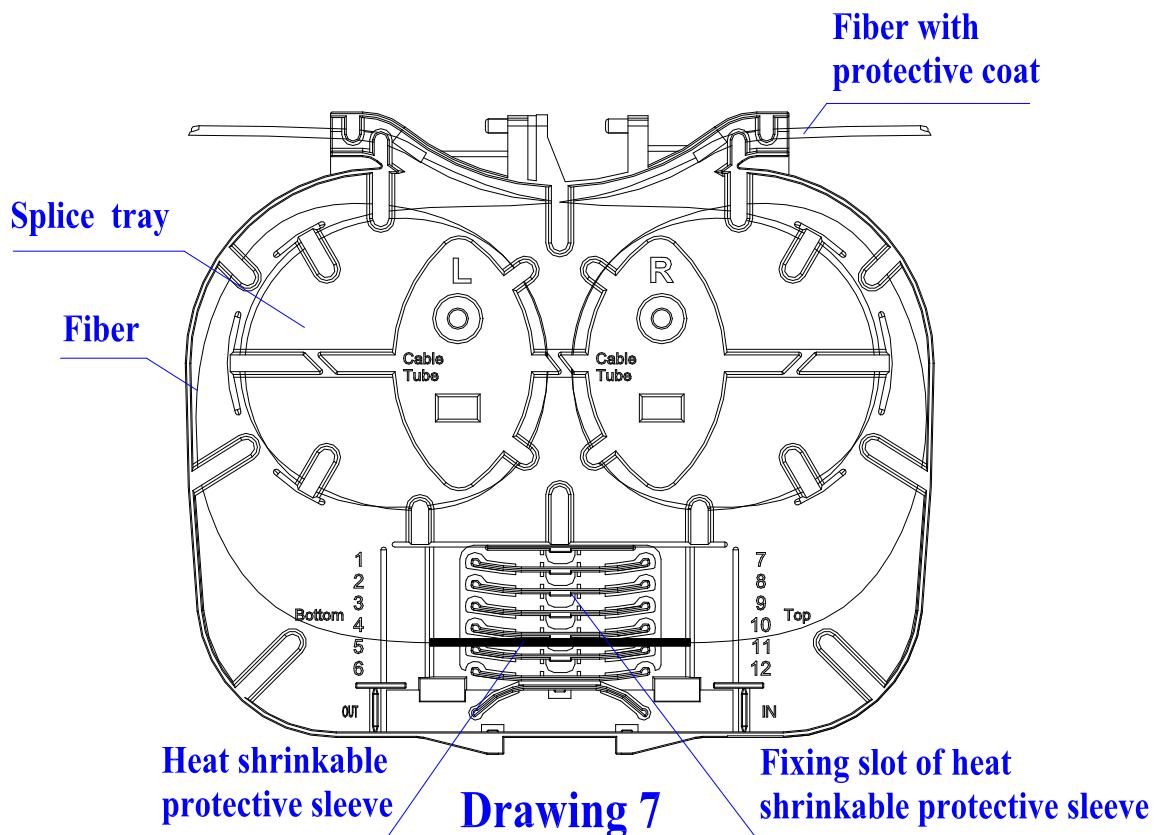

## 5.9 Step nine – Check up comprehensively.

5.9.1 The drop cable according to the appropriate route by the coil and fixed.

5.9.2 Drop cable routing see drawing 8.

5.9.3 For splitting and optical wiring, install the splitter as shown in the drawing 2, coil and fixed the input and output pigtails..

5.9.4 Check whether the internal tightness and reinforced core are well tightened.

5.9.5 Check whether gasket ring is installed neatly and smoothly without any breakage. If not, level it up with seal tape. See drawing 9.

**Important issues:** If any problems occur, they should be solved right away.

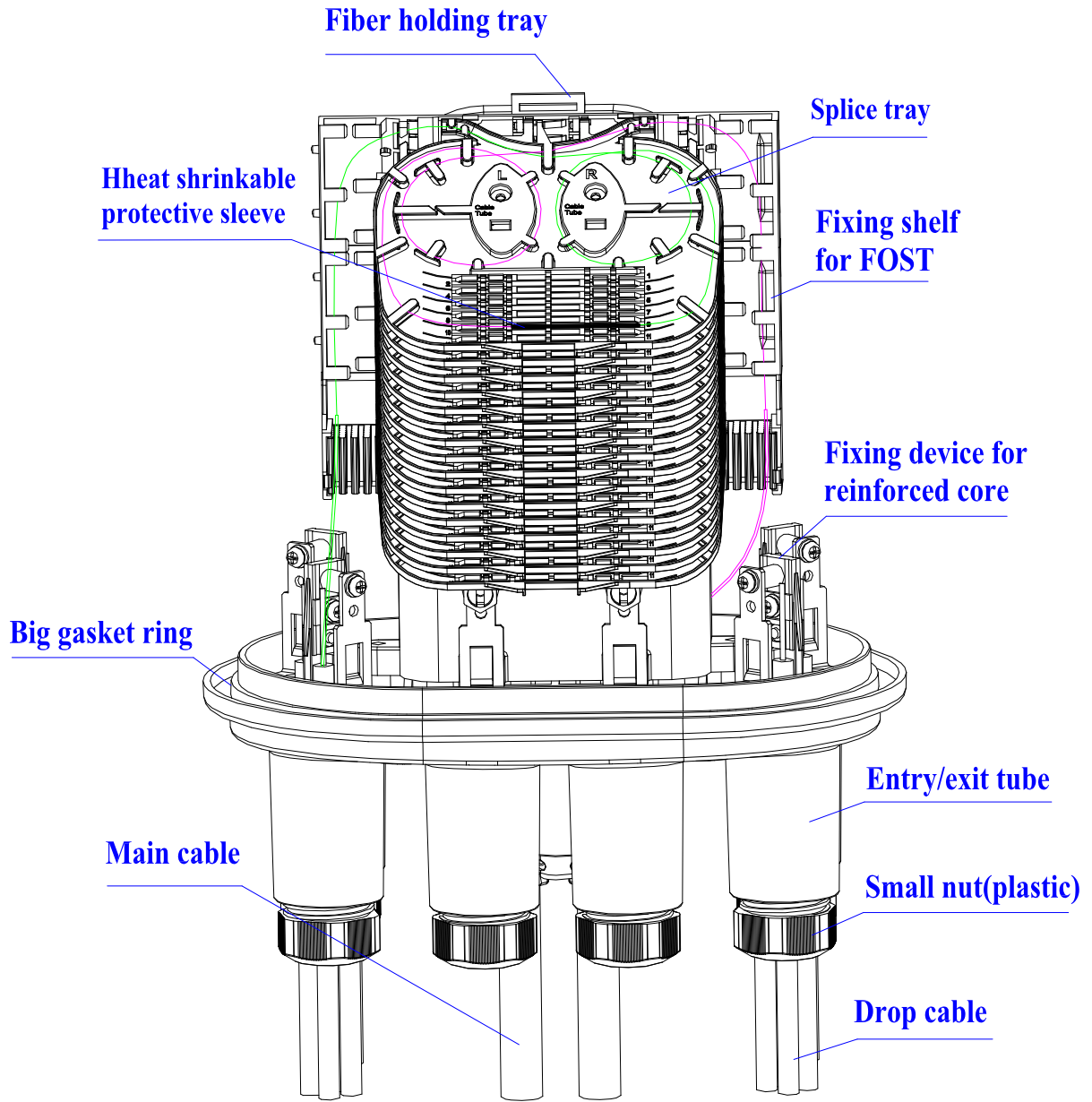

**Drawing 8**

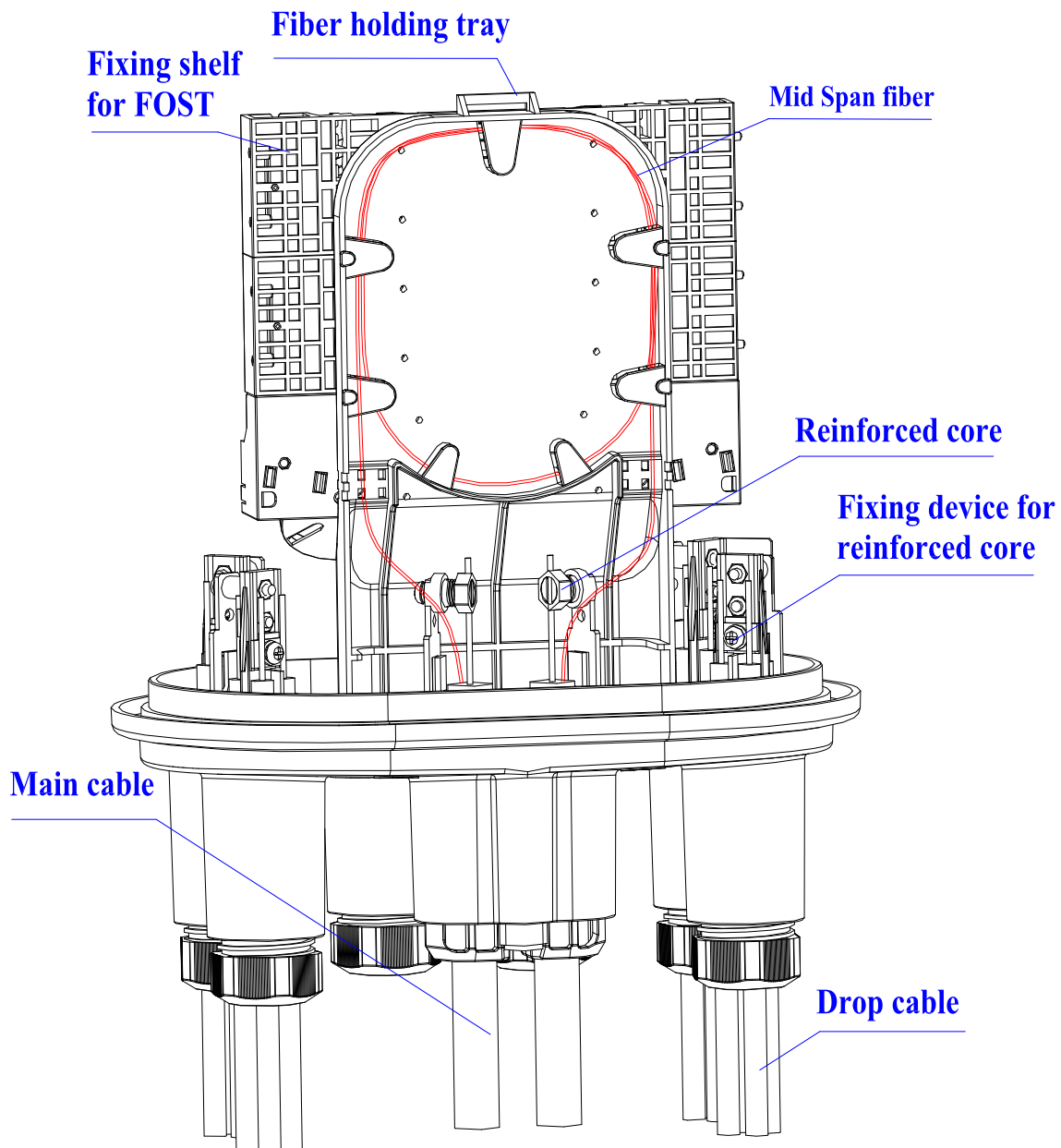

**Drawing 9**

### **5.10 Step ten – Assemble FOSC housing and fix FOSC**

5.10.1 Put the desiccant into the closure

5.10.2 Put FOSC cover on base directly.

5.10.3 Install plastic hoop between FOSC cover and the base, tighten hoop locking system, which is to be fixed by hoop fixing bolt then.

5.10.4 All nuts (plastic ones) of base need to be retightened once more.

5.10.5 FOSC installation

- (1) Wall-mounting: Installation of closure on the wall mounting accessories, then fixed on the wall by expansion screw. See drawing10
- (2) Pole-mounting: Installation of closure on the pole accessories, then fixed on the pole with hose clamps. See drawing11

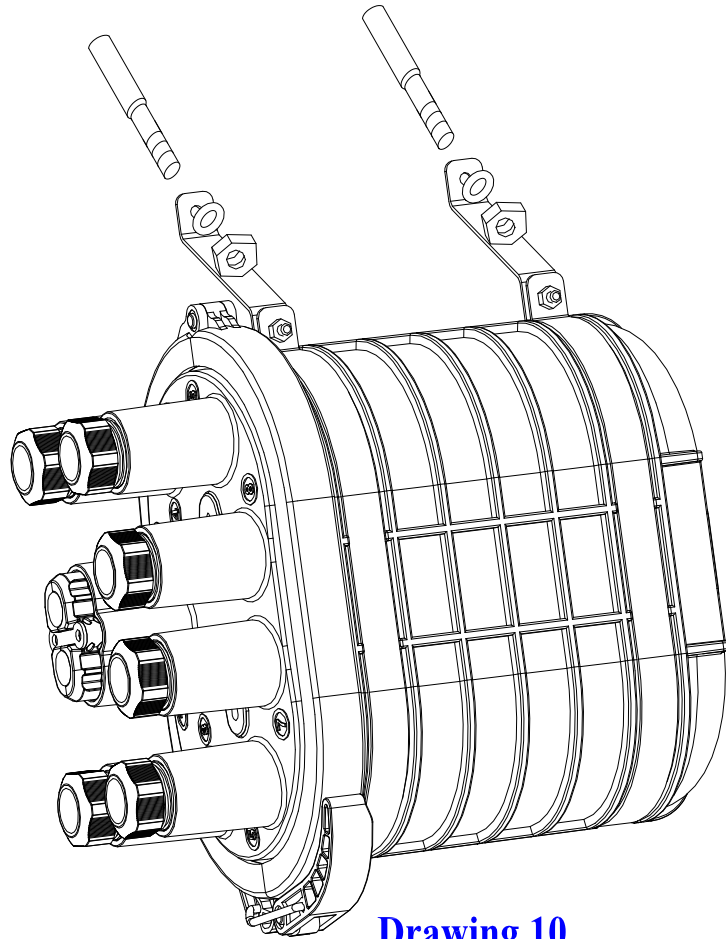

**Drawing 10**

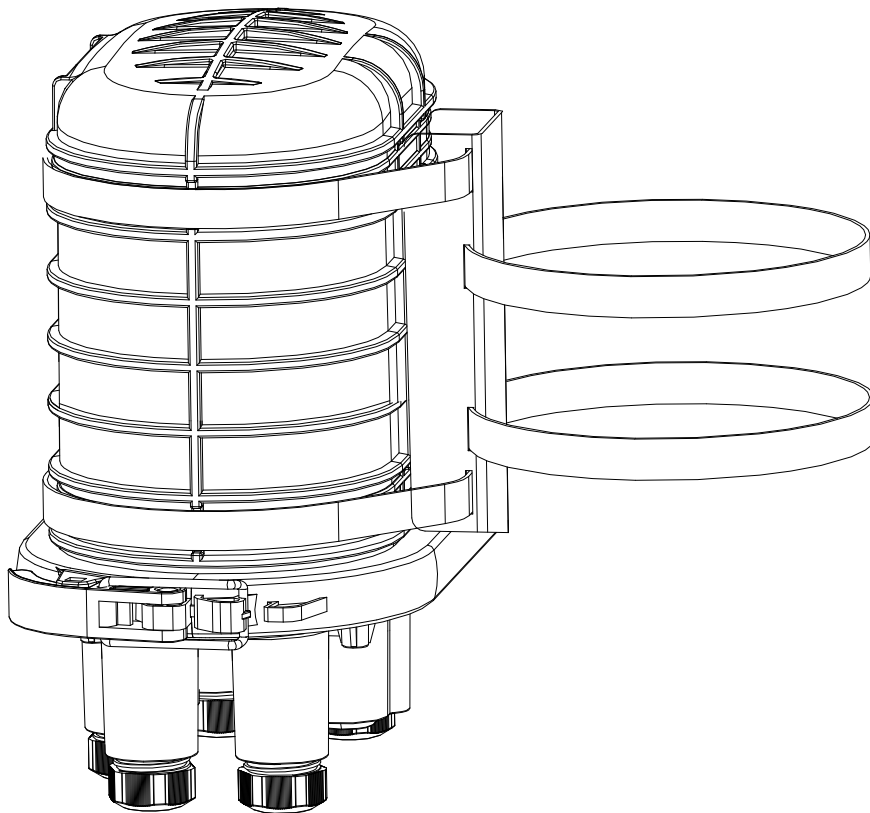

**Drawing 11**