

GJS-II-7002 Fiber Optical Splice Closure Specifications

Version:1.0



Official website



Technical specification



Installation guide



Download CN ver

GJS-II-7002 type fiber optic splice closure specifications

GJS-II-7002 cap type heat shrink cable connector box adopts innovative circular cap structure design, the box cover and the bottom of the box are locked and sealed with a hoop, and the cable is in and out of the single end. The main function of the product is to provide non-cutting straight-through + splicing and splicing + splicing and branch joint protection for various types of optical cables in the optical transmission link, which can play the role of straight-through, splicing, splitting and wiring. The shell of the product is made of modified PC engineering plastic, which has good physical and chemical properties, and is suitable for overhead, pole, wall hanging and underground installation.

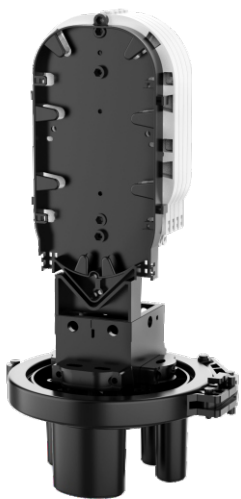

Reliable sealing

The cable connector box adopts heat shrink sealing structure design, the bottom has a large oval entrance and exit hole for the seal of the uncut straight-through cable, and a small entrance and exit hole for the branch cable and the introduction cable. High strength PC engineering plastic is used to make the joint box shell have longer service life and excellent sealing performance.

Modular design

The welding disc adopts a fast superimposed structural design, which can increase or decrease the number of welding discs according to the capacity.

Optical fibers with loose sleeves can be coiled and stored. The bending radius of the optical fibers is greater than 30mm.

Powerful Features

Support cable through inventory, bifurcation, docking and welding. It can be aerial, wall hanging, pole holding and underground installation.

The metal parts in the connector box can be grounded through the grounding device and grounding cable.

Excellent practicabilit

The shell of the joint box is made of modified PC material, and the internal metal parts are made of stainless steel material, which can meet the service life of more than 25 years (depending on the environment), and has good impact and corrosion resistance characteristics.

If necessary, the fitting box can also be fitted with a valve nozzle for the tightness test of the fitting box.

GJS-II-7002 type fiber optic splice closure specifications

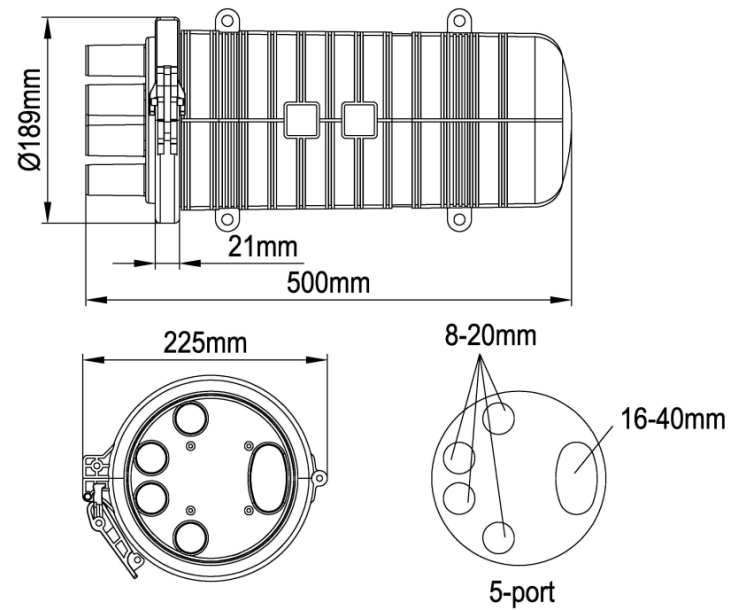
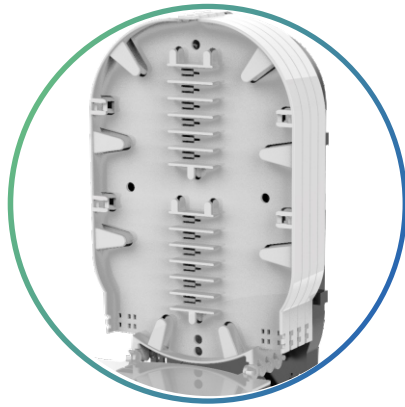

Product specifications	Splicing tray (bunchy)	Splicing tray (bunchy)	Splicing tray (ribbon)	Splicing tray (ribbon)
Maximum capacity	144 cores	192 cores	288 cores	288 cores
Capacity of each splice tray	12 core/tray	12-24 core/tray	72 core/tray	72 core/tray
Maximum number of splice trays	max 12 pcs	max 8 pcs	max 4 pcs	max 4 pcs
Number of optical cable entrance and exit tubes	1 oval port, 4 branch ports			

Ordering Guide

Accessories information



Product number
GJS-II-7002



Product size
500*Ø189mm



Product weight
3.9kg



Qty/CTN
4 set



Inner carton size
220*200*515mm



Outer carton size
460*420*535mm

Standard accessories

1. Labeling paper		6. Nylon tie	
2. Installation tape		7. Desiccant	
3. Abrasive cloth		8. Special wrench	
4. Heat shrinkable protective sleeve		9. Earthing wire	
5. Aluminum-foil paper			

Optional accessories

1. Pressure testing valve		7. Pole mounting	
2. Earthing deriving device		8. Wall mounting kit	
3. Buffer tube for bunchy fiber		9. Aerial mounting kit	
4. Buffer tube for ribbon fiber		10. Metal hoop	
5. Big heat shrinkable fixing sleeve I		11. Wall mounting kit	
6. Big heat shrinkable fixing sleeve II		12. Branching clip	

To the future together.

 www.ztong.com

 info@ztong.com

 Tel:86-0574-62498928

 Ningbo Zhantong Telecom Equipment Co.,Ltd.

 Fumin Industrial Zone,Moushan,Yuyao City,Zhejiang,China